

SET-UP / INSTALLATION INSTRUCTIONS
for MANUAL RESET DEVICES

04944-000	04944-040	04944-200, -240	04944-500	04944-600	04944-900
-----------	-----------	-----------------	-----------	-----------	-----------

Note: Seal unused conduit opening(s) with approved plug(s).

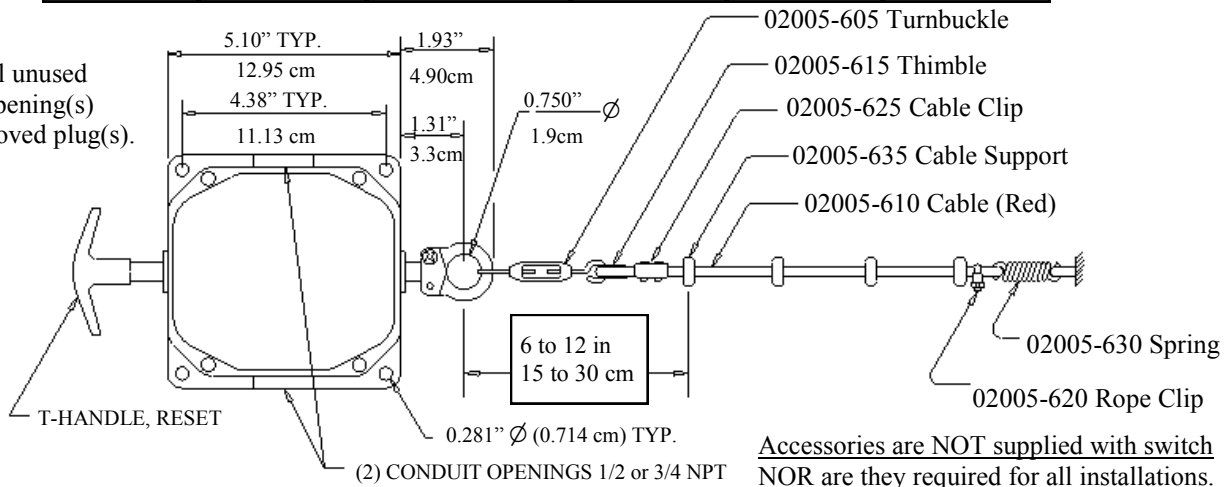

Since every installation is unique and separate, the following instructions can be considered flexible. There are some basic switch setup procedures that must be observed and they are indicated by the symbol (➤). The balance of the suggestions and information is subject to change to accommodate those most familiar and responsible for the installation.

INSTALLATION:

1. Observe all SAFETY REQUIREMENTS and PROCEDURES during installation, set-up and running.
2. N.E.C. and local wiring codes MUST be followed at all times.
3. The cable switch MUST be mounted on a flat surface! (Recommend 1/4-20 Bolts torque to ~60 in./lb. ~69 cm-kg)
4. Wire as required, torque each used terminal screw to 18 in.-lbs. (20.7 cm-kg).
5. Cover screws (4) SHOULD be tightened to 18 in.-lbs. (20.7 cm-kg) torque.
6. The first cable support SHOULD be located 6 to 12 in. (15 to 30 cm) from the switch. (see drawing on other side)
7. The first cable support SHOULD be located so that the cable is aligned with the switch shaft within 5 degrees.
8. It is recommended that the balance of the cable supports be spaced at intervals NOT exceeding 10 feet (~3m). Supports at properly spaced intervals are necessary to ensure that the cable weight will NOT affect switch operation.
9. The maximum recommended cable length is 200 feet (60.69m) and SHOULD be in as straight a line as possible.
10. Wiring SHOULD be through the motor control circuit. (See reference diagram below)

SET-UP and USE:

- 1. Secure (2 cable clamps per end are recommended) and adjust the SLACK cable length so that there is sufficient “droop” or “swale” in the cable between cable supports.
- 2. Pull the trip cable and then reset with T-handle to test and assure that the switch is functioning properly.
- 3. After applying control circuit power then repeat step # 2.
- 4. NOTE: All cable material will stretch with use and/or temperature variations. If the switch is set-up during extreme conditions a re-adjustment will be necessary to ensure proper switch function.

MAINTENANCE:

1. Regular Preventive Maintenance inspections are recommended.
2. Some conditions to watch for are:
 - a. Proper trip/reset tensions and slack within the trip cable.
 - b. Physical damage to the device.
 - c. Physical damage to the cable.
 - d. Frayed wiring.
 - e. Loose cable connections.
 - f. Any loose components.
 - g. Any worn components.
3. If other assistance is desired please contact the factory.

Warning—Danger

These products should only be used where point-of-operation guarding devices have been properly installed and maintained so that all appropriate OSHA and ANSI regulations and standards are met. Misapplication of these products on machinery lacking effective point-of-operation safeguards can cause serious injury to the operator of that machinery.

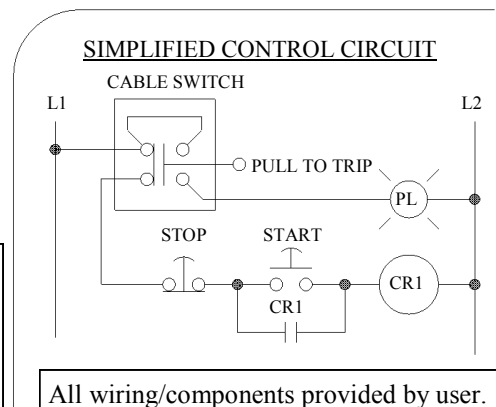

OPERATING SPECIFICATIONS

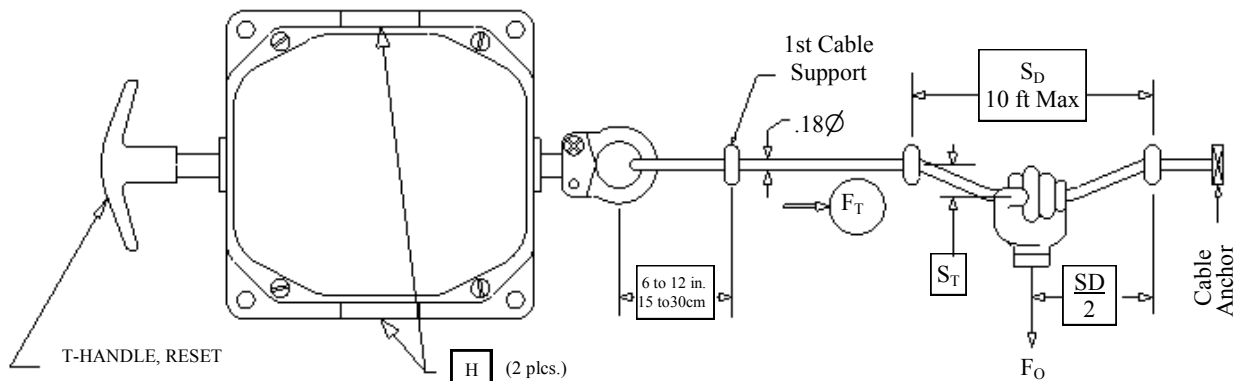

F_T = The value of force, along the cable, which trips the switch.

F_O = The value of force, applied by the operator perpendicular to the cable, which trips the switch.

S_D = The distance between the cable supports.

S_T = The distance the cable is deflected at the time of tripping. * S_T is in addition to any slack "droop" req'd for set-up.

Catalog Number	Contact Arrangement	Cable Anchor	Conduit Openings (H)	F_T Trip Force	$S_D = 5 \text{ ft.} / 1.5 \text{ m}$		$S_D = 10 \text{ ft.} / 3.0 \text{ m}$	
					F_O	S_T	F_O	S_T
04944-500	1 NO + 1 NC	Solid	1/2" NPT	10 lb. 4.5 kg	2.0 lb. 0.9 kg	3.5 in. * 8.9 cm	1.5 lb. 0.7 kg	5.0 in. * 12.7 cm
04944-600	2 NO + 2 NC		3/4" NPT					
04944-000	1 NO + 1 NC	Or Free i.e. vertical drop 02005-840	1/2" NPT	15 lb. 6.8 kg	4.5 lb. 2.1 kg	5.0 in. * 12.7 cm	3.4 lb. 1.6 kg	7.0 in. * 17.8 cm
04944-040	1 NO + 1 NC		1/2" NPT					
04944-200-240	2 NO + 2 NC		3/4" NPT					
04944-900	1 NO + 1 NC		1/2" NPT					

UL listed (File E 58589);

CSA certified (File LR 3648);

CE marked; **D marked** (File 17205)

These switches comply with UL-508; CSA—C 22.2 No. 14-M1987;

EN 60947-1:1997; EN 60947-5-1: 1997;

IEC Ratings:

Utilization = AC 15, DC 13; $U_e = 600 \text{ vAC}; U_e = 250 \text{ vDC}; U_i = 600 \text{ vAC}; U_{imp} = 2.5 \text{ kV}; I_{th} = 10A$

NEMA Ratings: AC = A 600; DC = N 300

Temperature: Operating = 0°C to $+55^\circ\text{C}$ (-32°F to $+131^\circ\text{F}$);

Storage = -40°C to $+85^\circ\text{C}$ (-40°F to $+185^\circ\text{F}$)

Fusing Requirements: 10A Slow Acting; 16A Fast Acting

Mechanical Life Rating = 150,000 operations

Operating Position: Can be mounted in any position.

Volts	A600 AC 15	
	Make	Break
24	60	6.0
120	60	6.0
240	30	3.0
480	15	1.5
600	12	1.2

Volts	N300 DC 13	
	Make	Break
24	2.2	2.2
125	2.2	2.2
250	1.1	1.1

AVAILABLE ACCESSORIES:

